

CC03-2VF Installation Manual



IMPORTANT SAFETY INSTRUCTIONS

1. Read and keep these instructions. Heed all warnings.
2. Do not use this apparatus near water.
3. Clean only with dry cloth.
4. Do not block any ventilation openings. Install in accordance with manufacturer instructions.
5. Do not install near any heat sources such as radiators, heat registers, stoves or other apparatus (including amplifiers) that produce heat.
6. Protect the power cord from being walked on or pinched particularly at plugs, convenience receptacles, and the power where they exit from the device.
7. Refer all servicing to qualified service personnel. Servicing is required when the apparatus has been damaged in a way, such as power-supply cord or plug is damaged, liquid has been spilled or objects have fallen into the apparatus, the apparatus has been exposed to rain or moisture, does not operate normally or has been dropped.
8. To reduce the risk of ignition of hazardous atmospheres, disconnect the equipment from the supply circuit before opening. Keep assembly tightly closed when in operation.
9. The maximum ambient temperature range is -40° to 122° F (-40° to 50° C).
10. Installation should be done only by qualified personnel and conform to all local codes.
11. Use only installation methods and materials capable of supporting four times the maximum specified load.



WARNING: To reduce the risk of ignition of hazardous atmospheres, disconnect the device from the supply circuit before opening. Keep assembly tightly closed when operating.



WARNING: To reduce the risk of ignition of hazardous atmospheres, conduit runs must have a sealing fitting connected within 2 inches of the enclosure.



TO REDUCE THE RISK OF IGNITION DO NOT OPEN WHEN AN EXPLOSIVE GAS ATMOSPHERE MAY BE PRESENT.

DISCLAIMER: Opticom Technologies Inc. will not be responsible for injuries or damages resulting from the improper installation or use of any product sold by Opticom Technologies Inc. their agents, distributors or dealers.

CAMERA DESCRIPTION

- 1/3" SONY ExView HAD II CCD Image Sensor
- 3.7~12mm Varifocal Auto-Iris Lens
- 700 TV Lines Resolution
- Minimum Illumination 0.01 Lux / F1.2
- -40F ~ 122F (-40C ~ 50C) Operating Temperature
- 12V DC Power

HOUSING DESCRIPTION/FEATURES

- Copper free die-cast aluminum body
- 3/4" NPT conduit feed-through hubs, offset for maximum clearance and capacity
- Optimized window viewing angle
- Internal and external ground screws and tamper resistant cover set screws for extra safety
- 3.35" diameter tempered glass window
- Buna-Nitrile rubber gasket for NEMA Type 4X watertight applications

FINISH

- Corrosion resistant Industrial and Marine Epoxy Coating.
- Chemical resistant
- Dry film resists bacterial attack
- Abrasion resistant
- Low VOC

PARTS LIST

- CC03-2VF CAMERA
- 12V DC 500mA Regulated Power Adaptor
- Allen Key (for housing cover set screw)

HOUSING DIMENSIONS

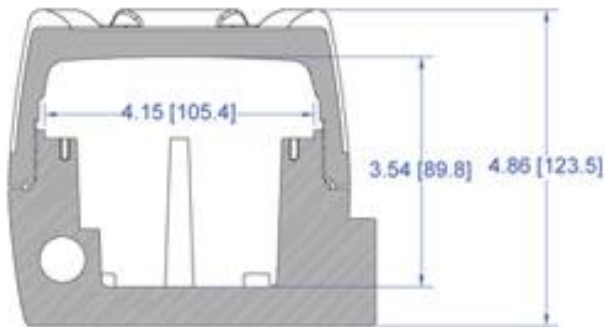
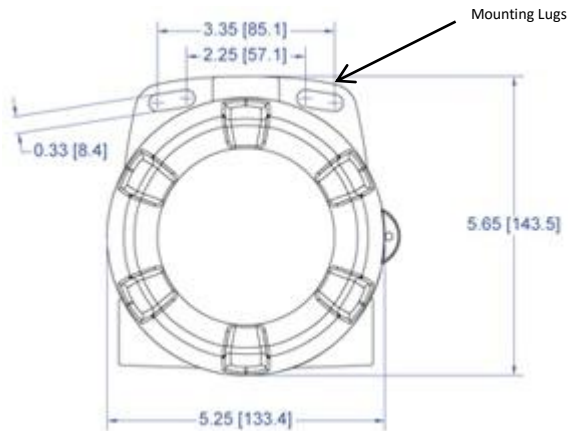

INSTALLATION

Install with the appropriate hardware to suit the mounting surface. Select a suitable location that is protected from accidental damage or tampering, and environmental conditions that could exceed the camera's general specifications. Ensure the selected location is protected from falling objects, accidental contact with moving objects, and unintentional interference from personnel. Follow all applicable building codes.

NOTE: Make sure the camera is correctly oriented when mounting – see picture below:

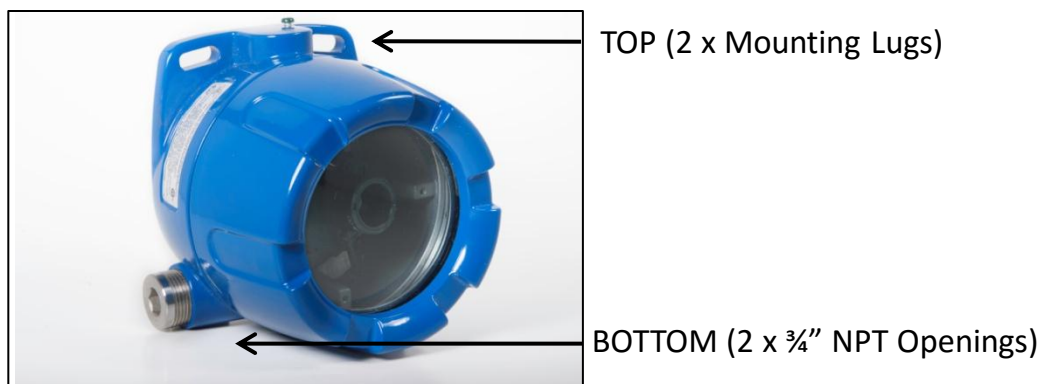

The "TOP" designation label on the housing indicates the correct upright viewing orientation for the camera lens.

The weight of the camera is 2.27 KG (5 lbs). It is recommended that all hardware used for mounting be capable of supporting four times the actual weight of the unit (ie: 10 KG or 20 lbs).

The camera must be bolted to the mounting surface using the 5/16" mounting lugs as shown in the picture above. Rubber washers should be installed on the housing side of the bolts to avoid damage to the epoxy housing finish. Fluorosilicone or Aramid/Buna-N type washers are recommended for maximum oil, abrasion, chemical and weather resistance.



CAUTION! Do not remove the housing cover when mounting the camera to prevent damage to the camera module and interior components. The housing cover should only be removed after mounting to allow for the focusing of the lens to the desired focal length. See details of lens focusing below.

ELECTRICAL

During installation, it is important to attach a 10 AWG copper stranded wire (**minimum requirement**) from the earth ground attachment point on the unit to an appropriate grounding location for your installation.

The camera is powered by 12VDC using LVT connected the 2.1mm power jack.



WARNING! CSA Certified / UL Listed CLASS 2 power adaptors must be used in order to comply with electrical safety standards. A UL certified power adaptor is included with the unit. For permanent installation using 12VDC adaptor in Canada ensure that a CSA certified adaptor is installed.

LENS FOCUSING

After mounting the camera, carefully remove the housing cover after loosening the set screw.



WARNING! Avoid thread damage. Never use force when removing or assembling housing cover. Ensure that the Buna-N rubber gasket is correctly positioned at the base of the threaded flange before reattaching the housing cover. Failure to correctly reinstall the housing cover will compromise the sealing of the unit.

Set Screw



Correctly Positioned Buna-M Rubber Gasket

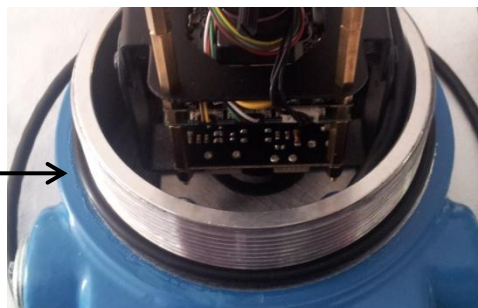

LENS FOCUSING

Removing the housing cover allows access to the varifocal lens adjustment screws. The CC03-2VF camera module is equipped with a 3.7~12mm varifocal lens allowing for a viewing angle of between 70 ° and 22 ° approximately. There are two adjusting screws below the infrared assembly. The upper adjusting screw controls the zoom (ie. focal length) while the bottom adjusting screw focuses the image after the focal length has been selected.



Connect the camera to the DVR or video processor. Adjust the focal length manually using the adjusting screws to obtain the desired image. A CCTV test monitor can also be used to adjust the focal length at the camera location. Tighten the adjusting screws and carefully reinstall the housing cover.

CC03-2VF Camera

Camera Specifications	CC03-2VF
Image Sensor	1/3" SONY ExView HAD II CCD
Resolution	700 TV Lines
Illumination	0.01 Lux / F1.2
S/N Ratio	More than 48 dB (AGC Off)
Lens	3.7 ~ 12.0mm Varifocal
Electronic Shutter	Auto (1/60sec ~ 1/100,000sec)
Sync System	Internal
Video Output	1 Vp-p / 75 ohms
Flickerless Mode	On
Gain Control	Hi / Low
White Balance	Auto
Backlight Compensation	Off (AES Off)
Gamma	r = 0.45
Power	12V DC
Power Consumption	120mA Max.
Operation Temp.	-40F ~ 122F (-40C ~ 50C)
Housing Specifications	
Construction	Epoxy Coated Die Cast Aluminum (Copper Free)
Color	Pantone 293 Blue
Ground Screws	Internal & External
Cover Set Screw	Tamper Resistant Cover Set Screws
O Ring	Buna N
Conduit Connections	2 x 3/4" NPT Standard Connections
External Mounting Holes	2 x 0.33in / 8.4mm
Dimensions (H x W)	4.86 x 5.65 inches / 12.4 x 14.4 cm
Weight	5 lbs (2.27 kg)