

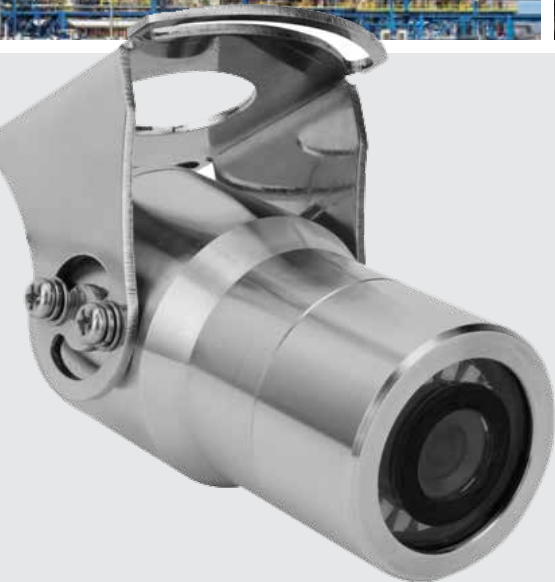

OPTICOM TECH

Industrial Video Specialists

**Opticom Tech's Industrial Video Solutions
Are Ideal For Oil & Gas Facilities.**



To increase the productivity and efficiency of oil & gas facilities a high quality and reliable video system is essential. Video cameras provide operators real-time monitoring from one or many locations, both onsite and remotely. Opticom CC03 Series intrinsically safe cameras are certified for use in all hazardous locations. Our CC06 Series cameras feature SS316 (AISI) housings for use in marine environments. All cameras are waterproof, dust resistant and rigorously engineered for reliable operation in any application. Opticom has camera solutions for oil rigs, loading facilities, refineries and gas plants.

Opticom Tech provides complete systems including industrial grade digital recorders and a full line of high definition LCD monitors. Real-time video solutions are available in IP, HD-TVI and analog formats and are fully scalable to any size of plant.

All systems are remotely accessible from any network connected PC whether locally or from around the world. Our video products are fully backed by our industry leading warranties, comprehensive technical support and exceptional customer service.

ADDITIONAL BENEFITS OF ADDING A VISUAL SYSTEM:

- Monitor operations
- Increase productivity
- Reduce downtime
- Improve security & safety

What is an Explosion-Protected Camera?

Explosion-protected cameras are cameras that are installed into heavy-duty industrial housings. The housings prevent explosions or inside sparks from escaping and igniting dust, fibers, gases or vapors in the surrounding air.



CC03-IP2MF36IR
Explosion Proof
Network Camera



CC03-IP2MVFIR
Explosion Proof
Network Camera



CC03-1F
Explosion Proof
Analog Camera



SVD-2400
Hybrid Analog/HDTV
Digital Video Recorder



CC06
Stainless Steel Series
IP Network, HDTV, Analog



SVN-2500P
IP POE Network Video Recorder



LCDI-215HDM
Industrial 21.5" Monitor

Opticom's Explosion Protected Enclosure Certifications

FM Approvals

Explosion-proof for Class I, Division 1, Groups B, C and D; Dust ignition-proof for Class II/III, Division 1, Groups E, F and G, hazardous (classified) locations, indoors and outdoors (Type 4X/IP66)

CSA

Explosion-proof for Class I, Division 1, Groups B, C and D; Dust ignition-proof for Class II/III, Division 1, Groups E, F and G, hazardous (classified) locations, indoors and outdoors (Type 4X/IP66)

OPTICOM

NORTH AMERICAN SALES - 800-578-1853

Fax: 888-370-5656

info@opticomtech.com

check out our 49 second video at **toughestvideocamera.com**